

# BLOCKVAGNAR Typ 20

500 kg  
1000 kg  
2000 kg  
3000 kg  
5000 kg





## BLOCKVAGNAR typ 20

500 kg • 1000 kg • 2000 kg  
3000 kg • 5000 kg

- Hörnskydd som förhindrar vagnen att lossa från balk
- Kullagrade löphjul
- Låg bygghöjd
- Klätterskydd under varje hjul
- Passar de flesta märken av lyftblock och teltrar
- Egna tillverknings nr samt provbelastade
- CE-certifikat medföljer
- Tredjepartstestad av SAQ Kontroll AB
- Bärbygel, vänster- högergångad

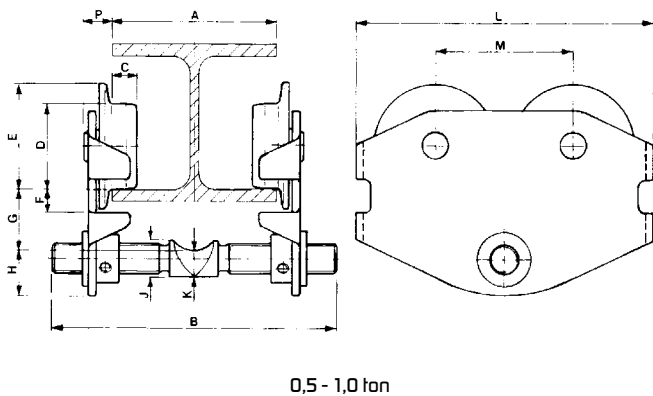

0,5 - 1,0 ton

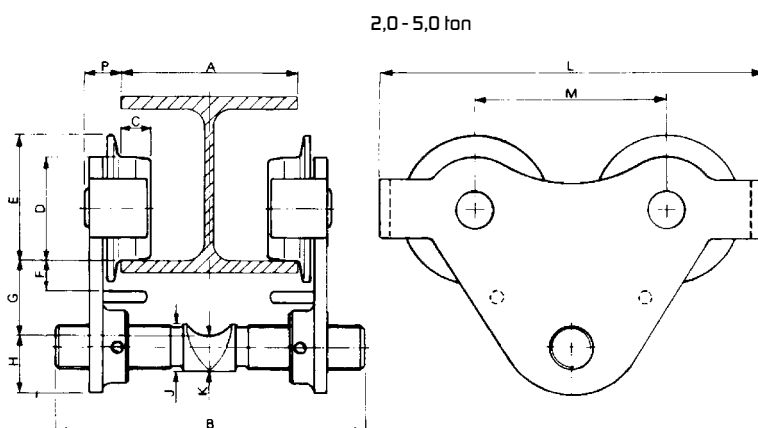

2,0 - 5,0 ton

W L L kg	Model	Gigant Art. nr	A min-max	B	C	ØD	E	F	G	H	ØJ	ØK	L	M	P	Min curve radius (m)	Weight kg
500	20123	3794-0509	46-160	208	18	62	77	18	45	33	25	19	216	100	22	1,0	6,0
500	20124	3794-1101	161-280	A+48	18	62	77	18	45	33	25	19	216	100	22	1,0	6,4
1000	20143	3794-0608	50-160	212	20	70	85	20	51	40	32	24	264	130	24	1,25	9,4
1000	20144	3794-1200	161-280	A+52	20	70	85	20	51	40	32	24	264	130	24	1,25	10,7
2000	20163	3794-0806	64-180	248	24	100	118	24	63	51	40	32	335	165	31	1,80	17,9
2000	20164	3794-1408	181-300	A+68	24	100	118	24	63	51	40	32	335	165	31	1,80	20,1
3000	20173	3794-0905	74-180	262	28	114	137	30	78	57	46	35	380	180	37	2,20	31,2
3000	20174	3794-1507	181-300	A+88	28	114	137	30	78	57	46	35	380	180	37	2,20	33,7
5000	20193	3794-1804	82-180	270	34	140	165	32	92	64	56	42	437	215	41	2,50	48,7
5000	20194	3794-1903	181-300	A+90	34	140	165	32	92	64	56	42	437	215	41	2,50	51,7

# GIGANT®

Gigant Arbetsplats AB, 441 80 Alingsås, Tel 0322-60 68 00, Fax 0322-60 68 40

www.gigant.se